

# HITZE

PRODUCER OF FIREPLACES

---

## OPERATING AND ASSEMBLY INSTRUCTIONS

Freestanding stove

**LUPO**  
**LYNX**  
**CANE**

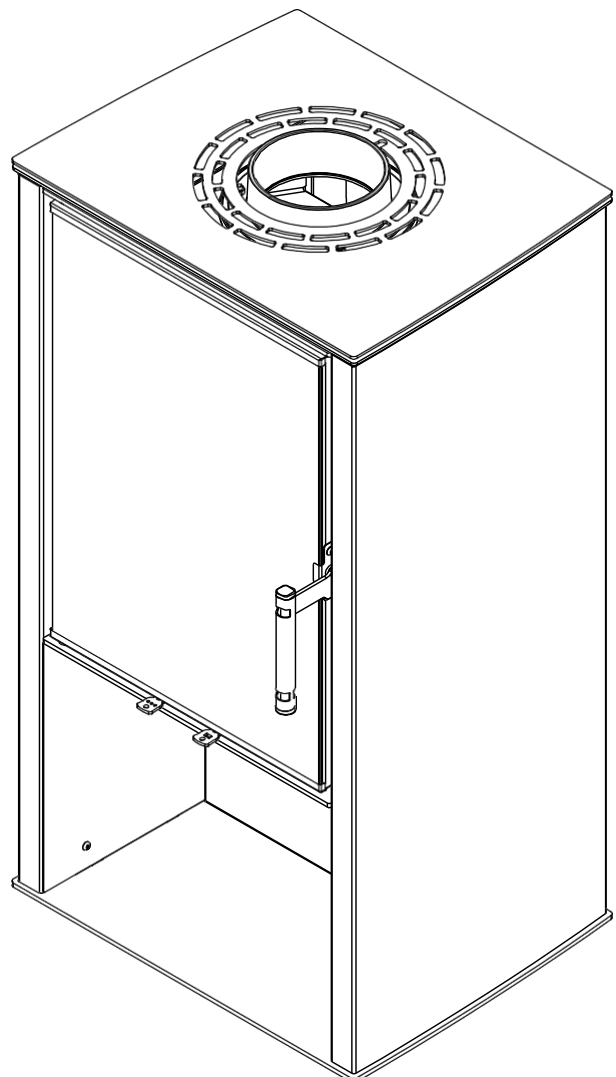

In compliance with the requirements of the  
Ecodesign Directive within the EU Member States:  
"This product cannot be used as a primary  
source of heating."

[www.hitze.pl](http://www.hitze.pl)

# Dear Customer,

Thank you for purchasing a Hitze freestanding stove!

---

**IT IS ESSENTIAL TO READ THE OPERATING AND INSTALLATION  
INSTRUCTIONS IN FULL BEFORE FIRST USE  
AND CHECK THE COMPLETENESS OF THE PRODUCT.**

# Table of contents

<b>1. INTRODUCTORY INFORMATION</b> .....	2
1.1. General information.....	2
1.2. In order to comply with the necessary safety rules, it is necessary to .....	2
1.3. Never .....	3
1.4. Hitze is exempted from civil and criminal liability in the event of .....	3
1.5. Purpose of the cooker.....	3
1.6. Construction and operation of the cooker .....	6
<b>2. TRANSPORT, ASSEMBLY, INSTALLATION OF THE COOKER</b> .....	7
2.1. Transport and handling .....	8
2.2. Assembly .....	8
2.3. Substrate recommendations.....	10
2.4. Flue pipe.....	11
2.5. Connection to flue pipe.....	11
2.6. The flue system shall meet the following features.....	12
2.7. Ventilation of the cooker .....	13
2.8. Installation of the cooker .....	13
2.9. Connection of hot air distribution system (DGP) .....	14
<b>3. STARTING UP</b> .....	16
3.1. Preparation for commissioning.....	16
3.2. Firing up the cooker.....	16
<b>4. USE</b> .....	17
4.1. Fuel types .....	17
4.2. Adding fuel .....	17
4.3. Preventing the escape of fumes .....	18
4.4. Glass cleanliness .....	18
4.5. Operation in adverse climatic and transitional conditions .....	18
4.6. Ash disposal.....	18
4.7. General comments.....	19
<b>5. CONSERVATION</b> .....	20
5.1. Recommended periodic cleaning of the cooker .....	21
<b>6. FAULTS AND ANOMALIES DURING OPERATION</b> .....	22
6.1. The most common anomalies and how to resolve them.....	22
<b>7. NAMEPLATE</b> .....	23
<b>8. INSPECTION CARD</b> .....	24

# 1. NEWS INTRODUCTION

**Warmth from Nature** - these words perfectly encapsulate the Hitze brand philosophy. In line with this philosophy, we manufacture fireplaces and cookers that burn wood or wood pellets, which are the least environmentally damaging raw materials. Thanks to modern technology, we have developed innovative solutions that are characterised by their modern design and high heating efficiency.

***We wish you trouble-free operation and plenty of warmth!***

**Before installing and connecting the cooker to the chimney system, it is essential to read the Operating and Installation Instructions and to check the completeness of the product components.**

The information contained in the Operating and Installation Instructions will ensure the correct operation of the cooker and will help to avoid damage and accidents due to improper use.

**If you have any doubts or operating problems, please contact your point of sale or the Manufacturer.**

## **NOTES:**

**The device must not be used by children.**

**Never leave children or pets unattended around a burning or just extinguished hearth.**

**Use protective gloves to open the oven door after and during use.**

**Danger of burns (hearth parts can be very hot).**

In order to improve the product, the Manufacturer reserves the right to make changes to the drawings, photographs and descriptions, as well as to the parameters of the equipment without prior notice and at any time. It is forbidden to copy the Operating and Assembly Instructions in whole or in part without authorisation from the Manufacturer. Keep the operating and assembly instructions out of the reach of children.

**In the event of damage, loss or destruction of the User's Manual and Installation Manual, please request a copy from the point of sale or from the Manufacturer, providing the identification details of the appliance.**

## 1.1. Information general

### **Security**

Compliance with the following rules will enable the cooker to operate correctly, avoiding damage and accidents caused by improper use.

### 1.2. To maintain the necessary safety rules :

- Before installing or maintaining the cooker, read and understand the Operating and Installation Instructions;
- Install the cooker in the most convenient position taking into account current building and fire regulations;
- installation, maintenance and functional testing of the system should be carried out by qualified specialists;
- use the appliance for its intended purpose;
- It is imperative that the cooker is adequately ventilated and supplied with air at the place of installation;
- Place the clothes dryer at least 1.5 m away from the cooker (fire hazard);
- check the permissible load on the floor (floor, ceiling) at the intended location of the cooker (taking into account the total weight of the unit including its installation);
- provide a suitable chimney installation to guarantee safe use (e.g. a chimney made of non-combustible materials with low heat absorption);
- avoid installing the cooker in rooms where there are B-gas appliances, hoods (with and without extractor hoods), heat pumps, collective ventilation ducts, numerous active smoke ducts, as well as

in the vicinity of stairwells and rooms with equipment capable of creating negative pressure;

- **avoid direct contact with the cooker (the appliance gets very hot during operation) and if necessary use suitable protective equipment (clothing, heat-resistant gloves);**
- Install the cooker in a room with fire protection, equipped with a fresh air supply and smoke extraction;
- in the event of any difficulties, contact the dealer or manufacturer (in the event of repair, request original spare parts);
- periodically check and clean the flue pipe in accordance with the regulations in force;
- Include operating and installation instructions in case the unit is sold or rented.

### 1.3. Never belongs:

- resist and climb on the cooker;
- use the appliance in the event of faults or malfunctions;
- leave flammable materials within 1.5m of the cooker;
- light fires with flammable materials and burn waste.

### 1.4. Hitze is exempt from civil and criminal liability in the event of:

- use of the cooker not in accordance with the Operating and Installation Instructions;
- modification of the cooker and unauthorised substitution of non-original parts (these actions lead to immediate cancellation of the guarantee);
- injury and material damage caused by incorrect installation and maintenance (not in compliance with the Operating and Installation Instructions).

### 1.5. Purpose cooker

The cookers provide an additional source of heat in the rooms in which they are located. These appliances have a fixed-burner hearth, with manual fuel loading, closed with a standard (hinged) door. The main fuel is seasoned hardwood (beech, hornbeam, birch) with a moisture content of less than 20%. During combustion, heat energy is released from the combustion chamber by convection and radiation.

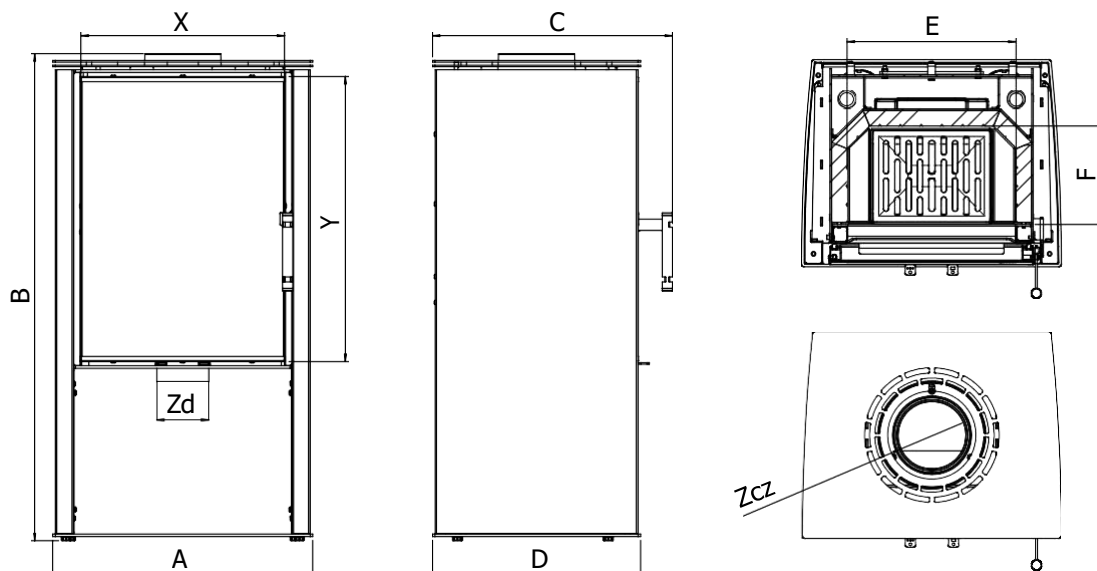
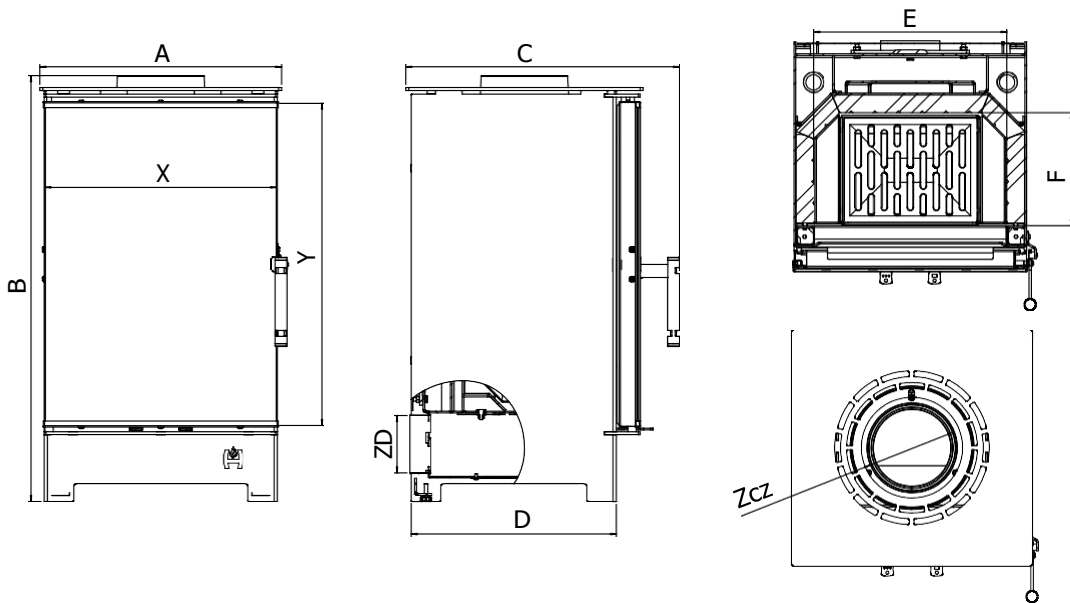

Fig. 1 LUPO dimensions

Dimensions [mm]		LUPO S	LUPO M	LUPO L
Width	<b>A</b>	502	657	992
Height	<b>B</b>	940	940	940
Overall depth	<b>C</b>	465	465	465
Carcase depth	<b>D</b>	400	400	400
Firebox width	<b>E</b>	326	481	816
Burner depth	<b>F</b>	190	190	190
Air intake diameter	<b>Zd</b>	100	100	100
Flue diameter	<b>Zcz</b>	150	150	150
Glazing width	<b>X</b>	390	545	880
Glazing height	<b>Y</b>	545	545	545

**Table 1** LUPO dimensions



**Fig. 2** LYNX cooker dimensions

Dimensions [mm]		LYNX S	LYNX B
Width	<b>A</b>	407	453
Height	<b>B</b>	720	760
Overall depth	<b>C</b>	465	506
Carcase depth	<b>D</b>	346	433
Firebox width	<b>E</b>	326	326
Burner depth	<b>F</b>	190	190
Air intake diameter	<b>Zd</b>	100	100
Flue diameter	<b>Zcz</b>	150	150
Glazing width	<b>X</b>	390	365
Glazing height	<b>Y</b>	545	515

**Table 2** LYNX cooker dimensions

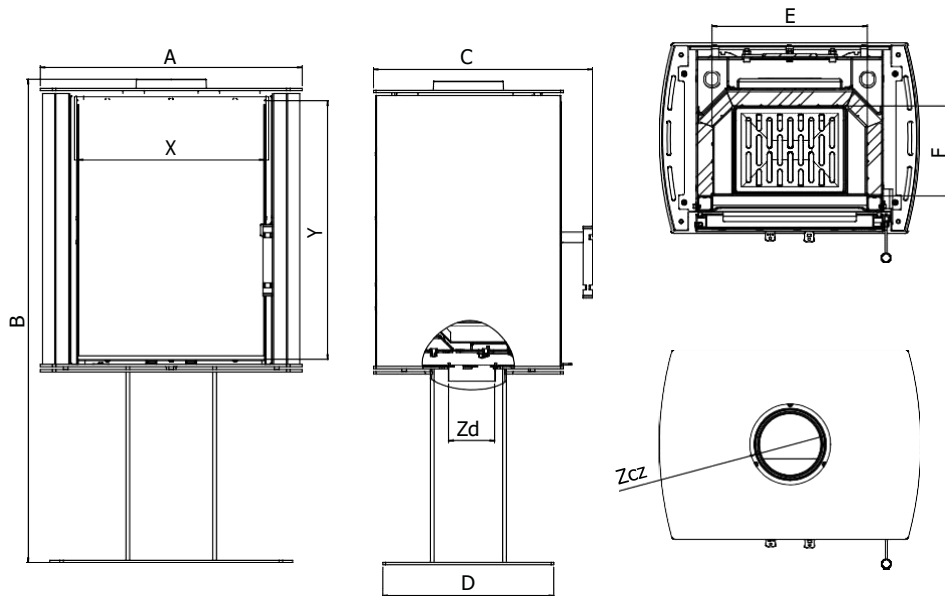

**Fig. 3** CANE dimensions

Dimensions [mm]		CANE S	CANE SF
Width	<b>A</b>	550	550
Height	<b>B</b>	1020	1020
Overall depth	<b>C</b>	465	465
Carcase depth	<b>D</b>	400	360
Firebox width	<b>E</b>	326	326
Burner depth	<b>F</b>	190	190
Air intake diameter	<b>Zd</b>	100	100
Flue diameter	<b>Zcz</b>	150	150
Glazing width	<b>X</b>	390	390
Glazing height	<b>Y</b>	545	545

**Table 3** CANE dimensions

## Technical data:

parameter s	unit	LUPO S, CANE S, CANE SF LYNX S, LYNX B	LUPO M	LUPO L
Rated power	<b>kW</b>	6,5	8,8	11
Heating load range	<b>kW</b>	3-8,5	4,5-11,5	5,5-14
Maximum fuel loading weight	<b>kg</b>	1,5	2	2,5
Average fuel consumption	<b>kg/h</b>	1,9	2,6	3,3
Thermal efficiency	<b>%</b>	83,5	83	82
CO emissions (at 13% O <sub>2</sub> )	<b>g/m<sup>3</sup></b>	1,08	1,001	0,921
Pollen emissions (at 13% O <sub>2</sub> )	<b>g/m<sup>3</sup></b>	0,038	0,033	0,028
Average flue gas temperature	<b>°C</b>	239	235	230
Dimensions of the fireplace glass	<b>mm</b>	390x540	540x540	880x540
Maximum length of billets	<b>mm</b>	350	400	400
Weight	<b>kg</b>	112	140	194
Fuel type	Recommended seasoned hardwoods (beech, birch, hornbeam)			
Fuel moisture	between 12 and 20			

Table 4 Technical data

## 1.6. Construction and operation of cooker

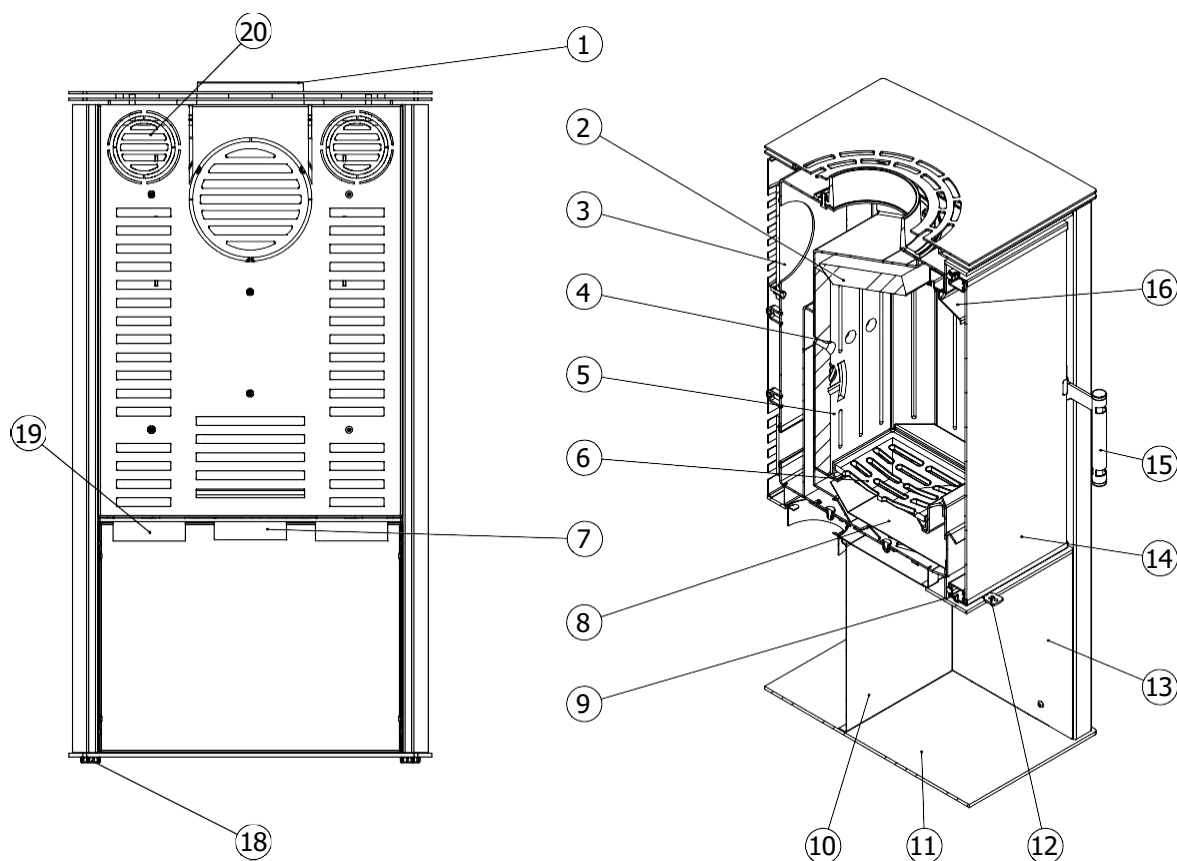



- |   |   |                                  |
|---|---|----------------------------------|
| 1. flue                                   | 8. ashtray                                | 14. side protection              |
| 2. deflector                              | 9. special profile doors                  | 15. decor glass                  |
| 3. flue cap                               | 10. back plate                            | 16. handle                       |
| 4. afterburning system                    | 11. base plate                            | 17. air curtain                  |
| 5. combustion chamber with insert ceramic | 12. adjustment lever secondary air damper | 18. levelling screws             |
| 6. cast iron grate                        | 13. throttle control lever primary air    | 19. connection of the DGP system |
| 7. air intake                             |   | 20. connection of the DGP system |

**Fig. 4 Construction of the furnace**

## Construction:

The cooker is made of boiler steel grade P256GH, 3 mm thick. The inside of the combustion chamber is lined with a ceramic heat preserving insert **5**. The design allows the flue gases to be led out through the upper or rear wall of the cooker. The air intake **7** is 100mm in diameter, the flue **1** 150mm. The cooker is suitable for use with a hot air distribution system (DGP) **18,19**. The front of the cooker consists of a steel door made of special profile **9** and profiled sheet metal, heat resistant glass **15**, and a handle **16**, which, thanks to its special design, remains cool while burning. The door is bolted to slats fixed to the cooker body.

## Activity description:

The air enters the cooker through an inlet grille **7**. There are two air inlet systems - primary and secondary. The amount of incoming primary air is regulated by the right-hand regulation lever on the front of the cooker under the door **13**. The air then flows around the ash pan **8** and enters the combustion chamber **5** through the grate **6**.

The amount of secondary air is regulated by the left lever **12** on the front of the cooker. The air is directed to the upper part of the combustion chamber **4** to postcombust the flue gases which improves the thermal efficiency and reduces the amount of pollutant-

The air volume is adjusted. The air volume is adjusted by pulling the lever to open the air inlet, and pulling it in to close the air inlet.

The cooker is also equipped with an air curtain **17** to help keep the glass clean. Above the combustion chamber there is a special ceramic plate called deflector **2**, which enhances the heat exchange. During combustion, the hot gases flow around the deflector and then through the flue **1** and the ducts into the chimney. The environment around the cooker is heated in two ways - the air surrounding the insert is heated (convection) and escapes through the ventilation slots in the furnace casing. In addition, heat radiates directly from all hot parts of the cooker.

## 2. TRANSPORT, ASSEMBLY, INSTALLATION COOKER

The device complies with EN 13229:2002 and is CE certified.

**Before assembling, installing and operating the cooker, read the following Operating and Installation Instructions carefully and follow the instructions given therein. This will ensure a safe and efficient operation of the cooker. Failure to observe these Operating and Installation Instructions may invalidate the warranty and endanger the user's life and limb.**

National and local regulations and standards must be observed during assembly, installation and operation, in particular:

- Regulation of the Minister of Infrastructure of 12.04.2002. Dz.U.Nr75, poz. 690 with amendments of 07.05.2004. r. Dz.U.Nr109, pos. 1156;
- Standard PN - B - 03406 :1994 Heating. Calculation heat demand;
- Standard PN - 89 / B - 10425 Smoke, flue and ventilation ducts made of brick;
- Standard PN - 78 / B - 03421.Ventilation and air conditioning. Design parameters of indoor air;
- Standard PN-EN 13229:2002 "Fireplace inserts including open fires for solid fuels. Requirements and tests".

**It is a requirement that the cooker is installed by a qualified person or company and that technical acceptance is carried out by a master chimney sweep and a fire specialist.**

Sequence of work for cooker installation:

- Preparing the location where the cooker is to be installed, checking the load-bearing capacity of the ground
- connecting the cooker to the chimney and making an air intake;
- using the cooker and observing whether there are any faults or anomalies (approximately 2 weeks).

## 2.1. Transport and handling

- The cooker is delivered pre-assembled, fixed to a pallet and wrapped in stretch foil;
- transportation of the cooker should be done in an upright position;
- After unpacking, check the cooker for transport damage;
- Unpack the cooker close to the installation site; take care when moving it (preferably with a trolley) (pay attention to the door and the glass);
- cooker packaging materials are not toxic or harmful; they should be recycled or stored by the user;
- in order to relieve the load on the cooker, in the event of installation in a difficult location, the ceramic inserts (which cover the firebox) may be removed; after installation, each element must be correctly put back in place.

## 2.2. Assembly

The design of the cooker allows 2 configurations. The flue can be on the rear wall or the top.

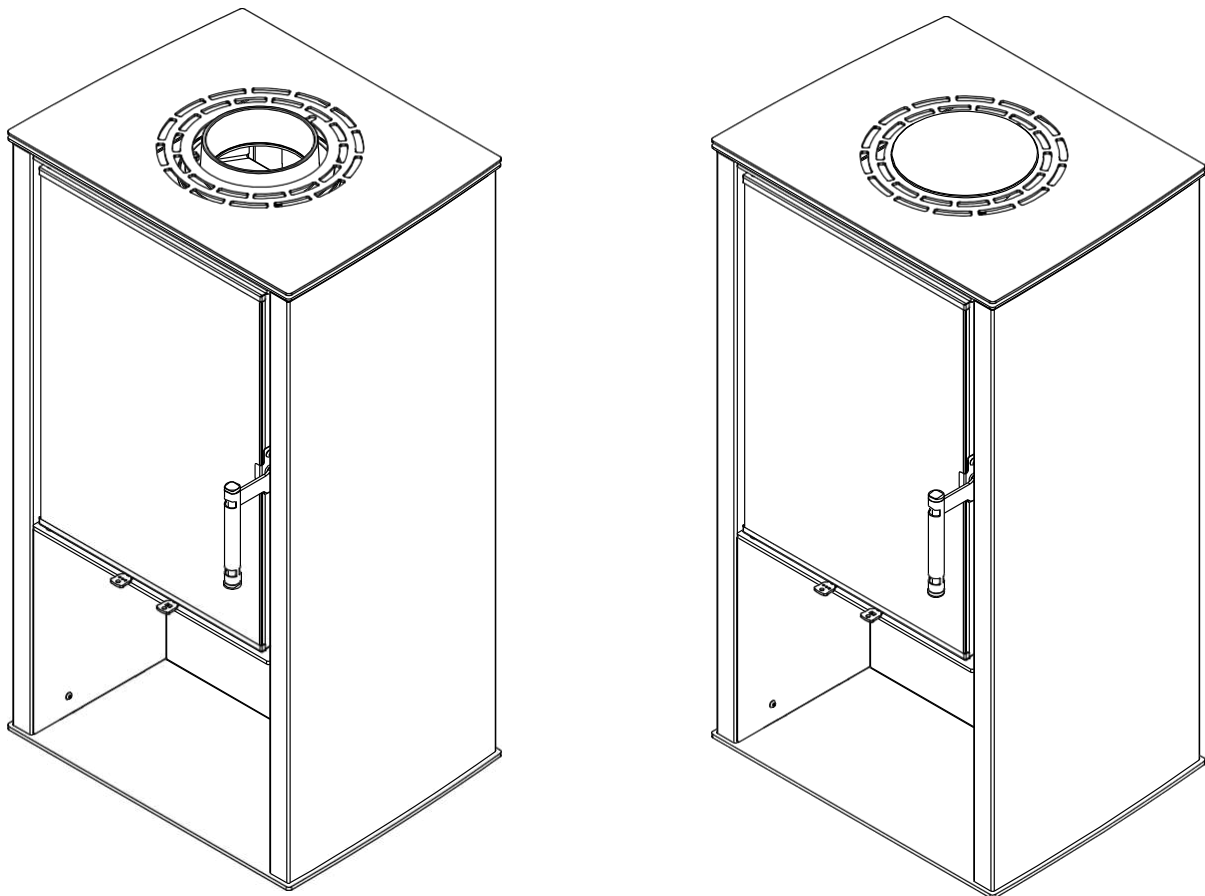

**Fig. 5** Cooker configuration

**The operation of transferring the flue from the top plate to the rear wall is shown in the drawing.**

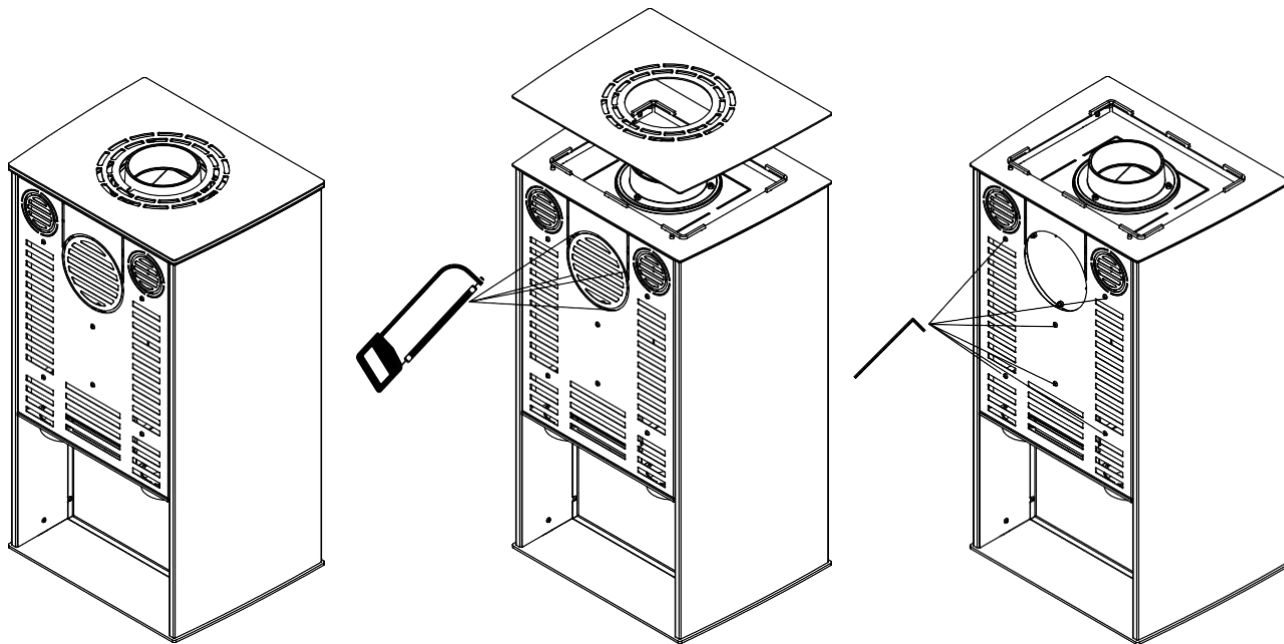

1. view of the cooker in its factory configuration,

2. remove the top cover, cut a hole in the rear panel with a hacksaw or cut a hole for the flue with pliers,

3. Using an allen key, unscrew the back plate,

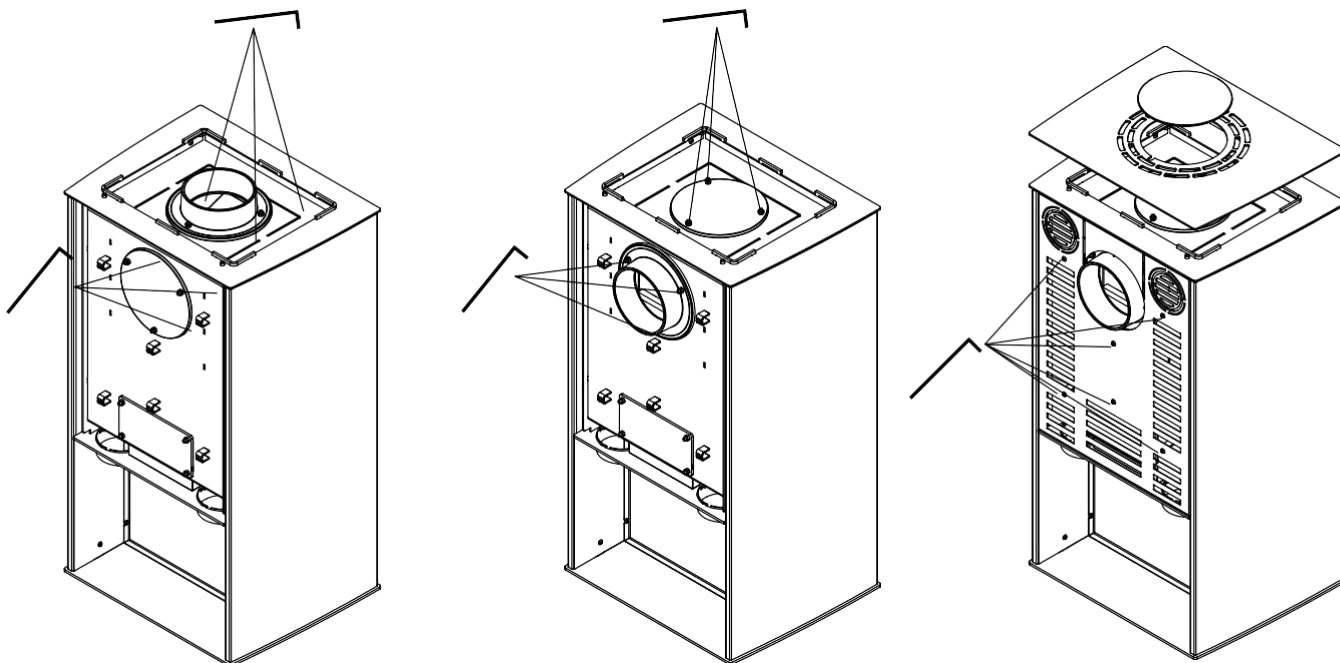

4. using an allen key, unscrew the flue and cap. in the rear wall of the cooker,

5. put the flue and the cap in place and screw them on,

6. screw the rear panel in place, put the top cover in place together with the hob.

**Fig. 6** | **Replacement of flue pipe**

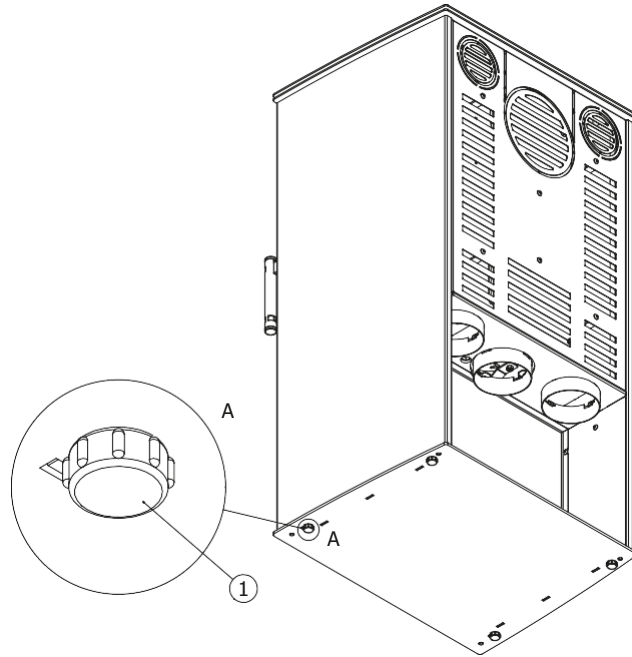

**Fig. 7** Tightening the feet

### 2.3. Recommendations for substrates:

- Before installing the cooker, check the load-bearing capacity of the floor (whether it meets the load-bearing conditions for the type of appliance depending on its weight);
- the floor must be made of a non-combustible material at least 30 cm thick, with a strip of space in front of the cooker door, at least 60 cm wide and extending beyond the edges of the door by at least 30 cm.

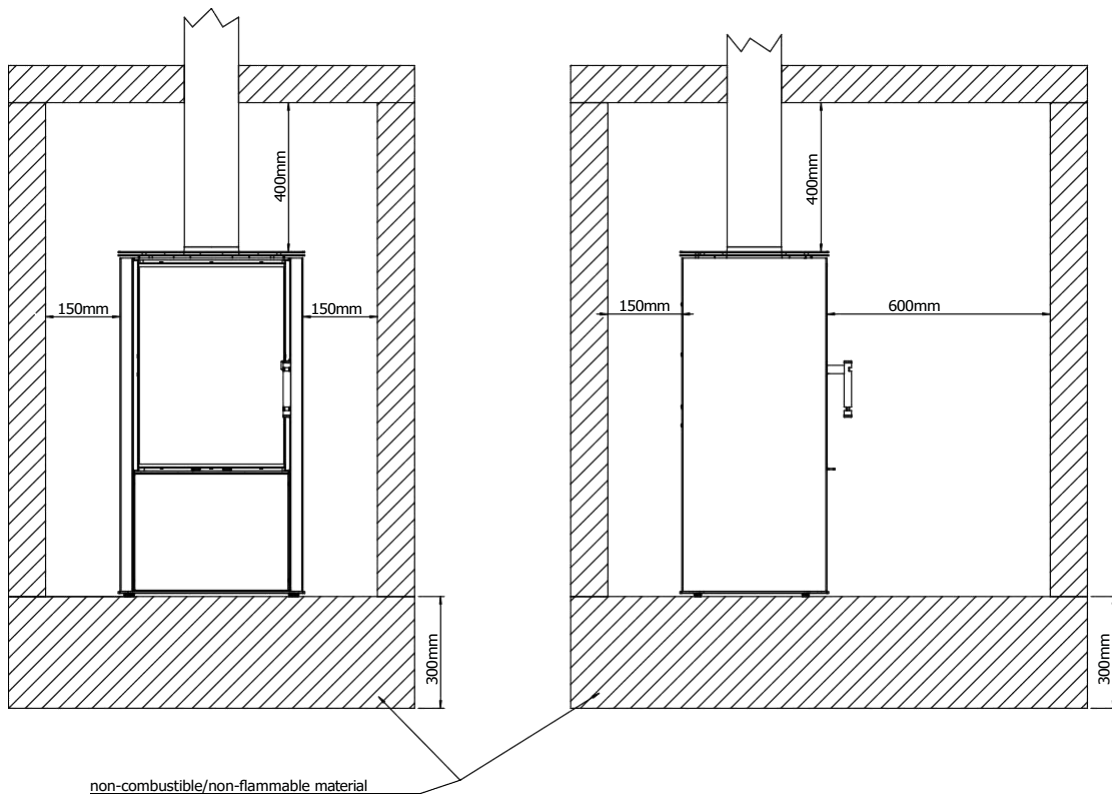

## 2.4. flue

The cooker requires a suitable cross-section of the flue pipe (flue duct) and a suitable height of the flue pipe. The cross-sectional area of the flue and smoke duct is determined according to the formula:

$$F = \frac{0.003 \times Q}{\sqrt{h}} \quad [\text{m}^2]$$

Where:

F - cross-sectional area of the flue and smoke duct [m<sup>2</sup>]; Q - rated thermal output of the insert [kW];  
h - chimney height [m].

According to current regulations, the flue must not be smaller than 14x14 cm, or its diameter must be at least 15 cm. Stoves with a higher output require a larger flue pipe cross-section. The cross-section also depends on the height of the chimney.

### **The cooker must be connected to a flue pipe or a riser pipe conforming to current national standards.**

The size of the chimney draught should be:

- minimum draught -  $6 \pm 2$  Pa;
- **AVERAGE, RECOMMENDED DRAUGHT -  $12 \pm 2$  Pa;**
- maximum draught -  $15 \pm 2$  Pa.

### **NOTES:**

#### **For proper cooker operation it is necessary to ensure a correct draught in the flue outlet:**

- Insufficient chimney draught causes poor operation of the cooker, excessive burial of glass and excessive contamination of the flue gas ducts; the overall heat output of the cooker is reduced (smoke leakage into the room can occur);
- A draught that is too strong can contribute to over-intensive combustion, high fuel consumption and lead to permanent damage to the cooker.

#### **Regular inspection of the chimney by a chimney sweep is recommended.**

## 2.5. Connection to the flue:

- Before proceeding with the installation of the cooker, an expert's opinion and selection of the flue pipe in terms of its technical parameters and condition must be carried out;
- The installation of the cooker may be carried out following a positive chimney sweep test of the flue pipe.

The flue pipe must comply with the applicable national or European standards.

In accordance with the operating and installation instructions provided, fit and connect the cooker to the chimney (including installation of screen plates - if used - and insulation of the flue pipe).

The manufacturer **does not recommend** assembling and installing the appliance yourself. In order to ensure a proper and safe start-up of the appliance and the fulfilment of the guarantee conditions, the assembly and start-up of the appliance must be commissioned by a person or a firm having the appropriate installation qualifications. The fitter is obliged to confirm in the Warranty Card (entry and stamp) that the installation has been carried out in compliance with the art. and valid legal regulations. Failure to do so will void the manufacturer's warranty.

## 2.6. The flue pipe system should meet the following features:

- the cross-section of the flue pipe must not be smaller than that of the flue pipe and must not narrow towards the chimney (adapters may be used to increase the diameter from the flue pipe to the chimney);
- the flue pipe should be as short as possible and have as few bends as possible (increase flow resistance, avoid condensation build-up);
- The cooker must not be connected to a flue pipe which is shared with another heating appliance;
- it is advisable to connect the cooker to a separate flue;
- the flue pipe may not have more than two inclinations of 45° up to a pipe height of 5m and 20° for pipe heights of over 5m;
- the flue pipe must be made of non-combustible materials and be thermally insulated;
- the flue pipe insulation should have a fire resistance of at least 60 minutes;
- a straight section of pipe at least twice the diameter of the cooker flue should be used at the exit from the flue;
- the joint should be made tight;
- The end of the chimney should allow for a smooth exit of the flue gases and be located at least 60 cm above the highest point of the roof;
- the connectors must be made of stainless steel 1.4401 (316), heat-resistant or fire-resistant steel adequately painted with a special paint and of an appropriate sheet thickness (heat-resistant and stainless steel 1 mm thick and fire-resistant 2 mm thick) - the material should be characterised by resistance to heat, acidity of the flue gas and condensate.

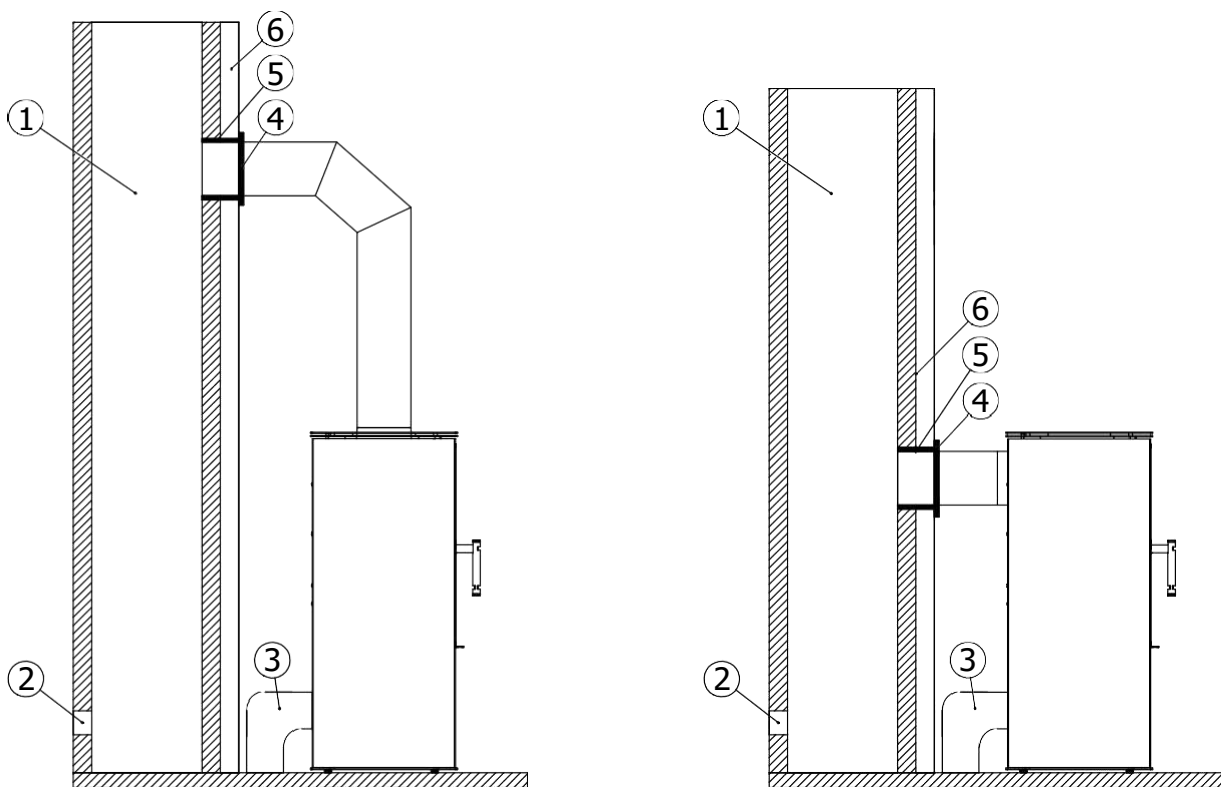

1. flue pipe,
2. the cleanout,
3. external air intake,

4. rosette,
5. sealing mortar,
6. non-combustible material.

## 2.7. Ventilation cooker:

- **It is necessary to provide fresh air from outside by unsealing the windows so that there is a constant supply of air. Too little fresh air from outside can cause poor combustion (production of carbon monoxide) and, in the worst case scenario, air with carbon monoxide can backflow through the ventilation ducts when the windows are tightly closed and there is a risk of fume poisoning;**
- The design of the cooker allows fresh air to be brought in from the outside (an air pipe with a diameter of 100mm is used). The pipe can be led from the wall behind the back of the cooker or, after turning the base, from the floor. It is also possible to bring the air in directly from the room where the cooker is located, provided that there is adequate ventilation to prevent the air supply from closing off automatically.
- it is assumed that the amount of air required to burn 1kg of wood is approximately 8 m<sup>3</sup>;
- when using an air distribution system to other rooms, in order to circulate the air freely, ensure that the cooled air is returned to the room where the cooker is installed (otherwise the operating cycle of the cooker may be disrupted and the heat distribution process may be impaired);
- When determining the location and installation of the unit, attention should be paid to the principles of correct air circulation and air balance in the room;
- Ventilation must be provided in the room where the cooker is installed;
- To ensure adequate convection space (cooling of the cooker, heating of the air) the cooker should be positioned at least 80 cm away from materials which could be distorted or damaged by the heat (furniture, panelling, wallpaper, etc.).

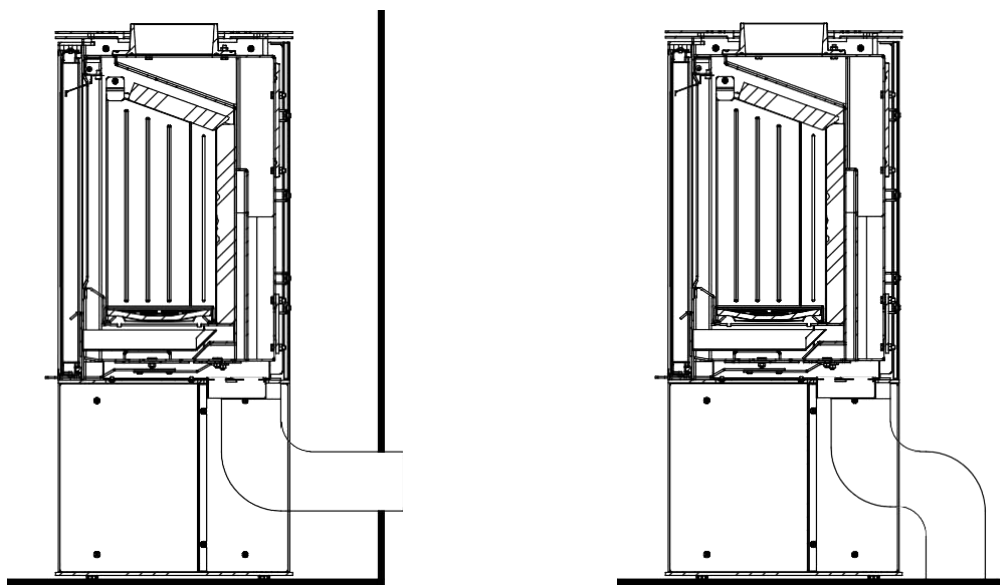

Fig. 10 Air intake connection diagram

## 2.8. Installation cooker

The unit must be installed in accordance with current building code standards.

**Installation and assembly of the cooker must be carried out by qualified professionals.**

- The cooker must be positioned at a safe distance from any flammable products (it may be necessary to protect the walls surrounding the cooker);
- The space in front of the cooker should be protected to prevent sparks which may fall out of the firebox when adding fuel. The minimum safe area is 60 cm in front of the cooker and 30 cm to the sides from the edge of the door. The surface can be protected with natural stone, floor tiles, or a dedicated glass base;

Fig. 9 Diagram of the connection of the cooker to the flue





- Do not install the cooker in bedrooms, bathrooms or rooms where there is another heating appliance without an independent air supply;
- The cooker is a unitary structure and does not require additional supports;
- The height (levelling) of the cooker can be adjusted by means of the feet (a maximum of 20 mm can be unscrewed);
- If it is necessary to raise the cooker above the feet adjustment, make a masonry base and place the appliance on it (do not remove the feet needed for levelling);
- If the door is not properly levelled, it will not work properly (it will not close properly);

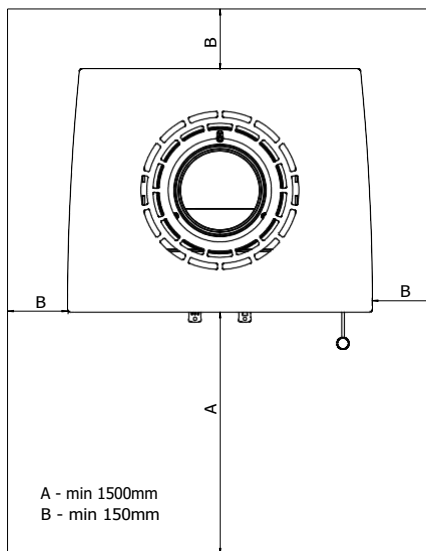
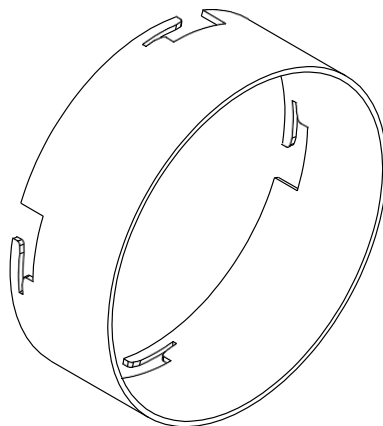

**Fig. 11** Safe area for flammable materials

## 2.9. Connection of hot air distribution system (DGP)

The hot air distribution system (DGP) allows the convection heat generated by the cooker to be used to heat other rooms. Different solutions are used depending on the output of the appliance and the installation conditions. The choice of the right one should be left to a person or company with experience in this field. In small single-storey houses, a simple gravity system works well. In larger areas, it is sometimes necessary to use forced-air blowers in the system.

Free-standing cookers allow the DGP system to be connected to the cooker in two ways: from above (LUPO, CANE, LYNX) or from below (LUPO, CANE). When installing from above, it is necessary to cut out sections of the rear cover at the locations marked on the drawing. Unobstructed airflow is gained. When assembling the pipes from below, a blower is required in the system to extract the heated air. The installation of the pipes is carried out using special fittings with a diameter of 100mm. The cut-outs allow mounting to thin or thick metal sheets.



**Fig. 12** Mounting connection with a diameter of 100 mm

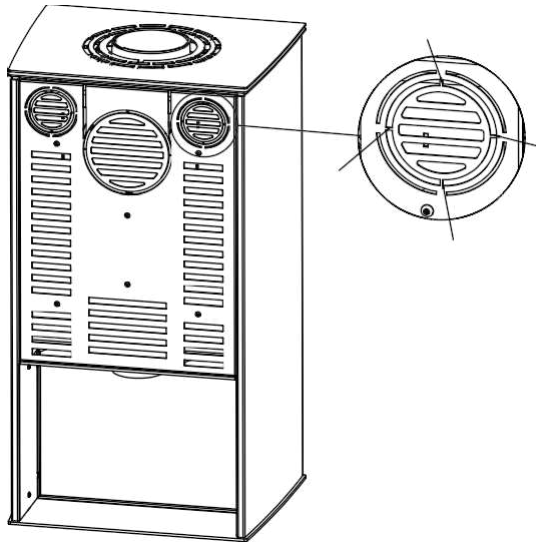

**Fig. 13** | The arrows indicate the cutting points before fitting the connectors when connecting from above

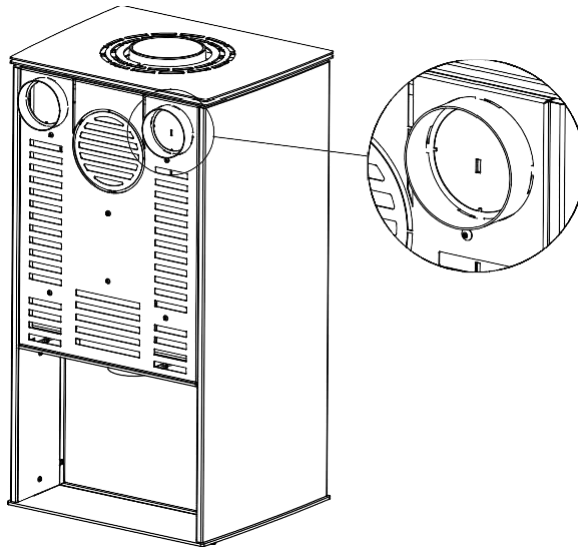

**Fig. 14** | Correctly installed connectors when connected from the top of the cooker

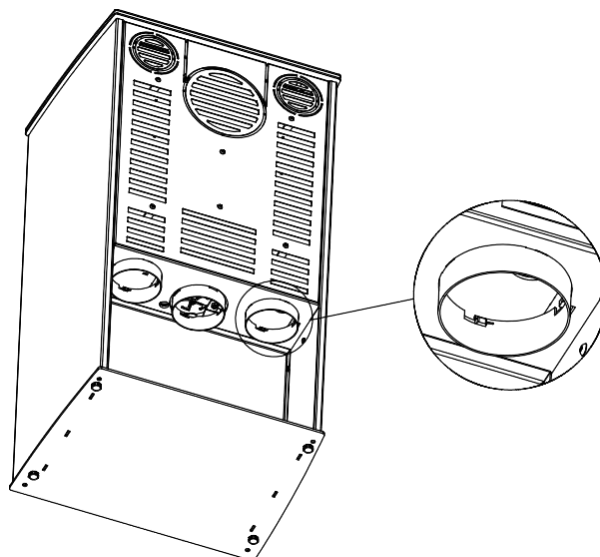

**Fig. 15** | Correctly installed connectors when connected from the bottom of the cooker

Pipes carrying the heated air to other rooms are placed on the properly installed connectors. For proper operation of the system, cool air must be returned to the room where the cooker is located.

### 3. STARTING UP

The initial start-up of the cooker, after it has been seated and properly connected to the chimney, must be carried out by the installer or an authorised service technician. The user must be present during commissioning so that he/she can be trained by the installer. The installer must refuse to commission the cooker if he discovers an installation fault which endangers the safety of the user. Correct commissioning must be confirmed in writing on the guarantee card.

#### 3.1. Preparation for launch

##### **Before firing up for the first time:**

- remove any stickers and other paper labels and accessories from the mantle body, ash pan or firebox that could be the cause of a fire, this also applies to transport protection;
- Check that the deflector(s), ceramic pieces and grate are properly seated, and that they have not fallen out of position during installation (If any seating faults are found, correct them. Otherwise the cooker may not operate correctly. In cooker types where the door is fitted with a multi-paned glass, check that during transport or use of the cooker the various parts of the glass have not come apart);
- check operation:
  - mechanism for regulating the air supply to the combustion chamber (cold-air dampers);
  - front door locking mechanism (hinges, handle);

#### 3.2. Firing up the cooker

##### **Before firing up the cooker:**

- put the thicker logs first in the firebox, then the smaller wood, and finally the small pieces (sub-sticks) - light with fireplace matches or a lighter;
- open the primary air control to maximum and the secondary air control to minimum;
- **the cooker door must be closed after lighting;**
- When the fire is burning well, use the air regulators to adjust the combustion air to a rather damped level (this means that only a small proportion of the primary air is supplied under the cooker grate; the secondary air damper is set at max. - the higher amount of air is supplied to the air curtain system, which protects the glass from scorching and to the post-combustion system at the front of the cooker; opening the air damper to 100% - as far as possible, results in very intensive combustion of the fire);
- it is advisable, in the final stage of combustion, to open the door and burn the remaining embers on the grate with a poker in order to better burn the fuel;

##### **NOTES:**

**As a large amount of air is fed under the grate and into the air curtain and flue gas afterburning system, too much fuel in the combustion chamber results in the production of a large amount of wood gas which results in a temporary sooting of the glass.**

**If the throttle is moved to the right as far as possible, the air supply to the combustion chamber is completely cut off, resulting in a gradual extinguishing of the firebox.**

**If necessary, the grate is unclogged with a poker.**

**During the first hours of operation, it is recommended to operate the cooker at a low load, i.e. up to 50% of the normal load.**

**The first ignition may be accompanied by condensation on the inner walls of the combustion chamber. This phenomenon is normal and results from condensation of the water vapour contained in the flue gases. It should disappear after the firebox has cooled down.**

**If flue gas is escaping from the cooker chamber, adjust the flue damper setting and increase the chimney draught.**

**Clean the hearth of ash residue before the next lighting.**

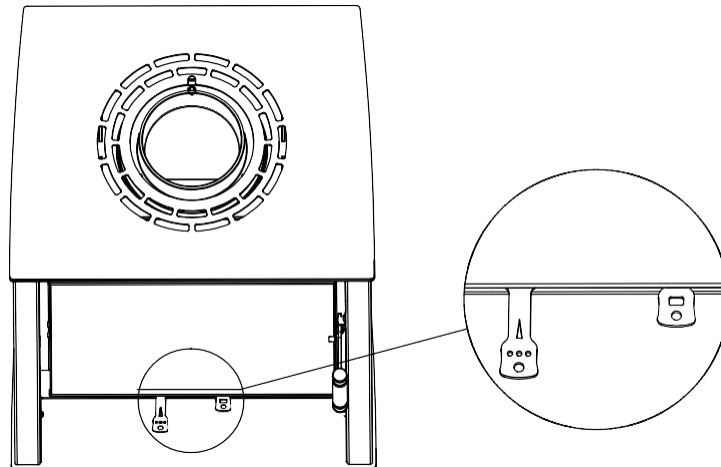

**Fig. 16** Throttle operation - pressed in - air supply closed, pulled out - air supply open

## **4. USE**

The surface of the cooker is coated with a special heat-resistant paint which, when the cooker is lit, first becomes soft (care should be taken not to scratch it) and then hardens. This process may cause an unpleasant odour during the first few burns. The manufacturer recommends ventilating the room intensively. If there are pets or birds in the room, relocate them temporarily. The manufacturer recommends that you keep the flame low and burn less fuel at a lower temperature for the first few days (approximately 2 weeks). This is to prevent cracks forming in the ceramic cladding, deformation of the structure, and damage to the cooker's protective coating (paint).

### **4.1. Types of fuel**

Due to the design of our appliances, the recommended fuel to be used is hardwoods such as oak, hornbeam, ash, beech and birch. **We particularly recommend birch.** The best fuel is seasoned wood (at least 2 years in an airy and dry place), in cut and split billets. We discourage the use of coniferous wood. Fresh wood or badly dried wood is not a good fuel, as it has limited energy properties. Burning improperly dried wood can lead to increased emissions of creosote deposited in the flue, which can cause chimney fires, overheating of the cooker, and glass breakage.

#### **NOTES:**

**It is prohibited to burn waste fuels, flammable liquids or other fuels not recommended by the cooker manufacturer.**

The manufacturer strictly forbids the use of coal, tropical wood, any type of product containing chemical compounds such as petrol, alcohol, naphthalene, oil, od- pads and laminated panels containing adhesives, varnish, etc. as fuel for the cooker.

### **4.2. Accuracy fuel:**

- The fuel is replenished when the flames disappear above the layer of embers in the firebox; it is best to rake the embers into a "pyramid shape" on the grate (on both sides in order to supply sufficient air from under the grate for the flame to appear) and to add the wood chunks;
- do not place embers on the grate at one level, as this significantly reduces the air supply to the grate and produces too much gas in the firebox, resulting in gasification of the cooker and possible explosion;

- Wood billets in the combustion chamber must be laid parallel to the plane of the door.
- before loading a fresh batch of fuel into the firebox, the grate should be ash-free and the ash container emptied if necessary.

### 4.3. Preventing the escape of exhaust gases

**To prevent fumes from the cooker escaping into the room when opening the door-check is recommended:**

- Approximately 10 seconds before opening the door, fully open the primary air regulator (throttle lever moved to the left as far as possible);
- Open the door slightly and, after waiting a few seconds (the time required for the smoke to be extracted), slowly open the cooker door;
- Be very careful when opening the door and after opening the door, as pieces of burnt fuel may fall out of the firebox;
- once the correct amount of fuel has been added, close the firebox door;
- After firing up the fuel, set the air regulator to the original position;
- The optimum amount of fuel is given in the table.

#### **NOTES:**

**The cooker manufacturer warns against overloading the cooker with fuel. Overloading may cause permanent damage to the structure of the appliance.**

### 4.4. Clean glass

**In addition to using the right fuel, keeping the glass clean is influenced by:**

- to provide an adequate supply of combustion air;
- optimum chimney draught;
- how to operate the cooker;
- use of fuel with a moisture content of less than 20%.

In order to keep the glass clean, it is advisable to add the recommended amount of fuel so that the fuel is central on the grate and as far away from the glass as possible.

If the glass becomes dirty during heating, we recommend increasing the combustion intensity by opening the air damper, as a result of which the glass will usually clean itself.

### 4.5. Operation in poorer climatic and transitional conditions

In the so-called transitional period or in poor weather conditions (e.g. fog, damp rainy days, strong gusty wind and when the outside temperature exceeds +15°C), the chimney draught may be impaired so that the flue gases are not fully discharged. To compensate for this adverse effect, load the cooker with as little fuel as possible or additionally use draught regulators.

### 4.6. Removal of ash

**Depending on the amount and type of fuel being burned:**

- using a poker, scrape the ashes through the grate into the ash pan;
- After collecting the ashes, remove the ashpan and empty it;
- The ashtray can only be emptied when it is cold; we recommend that this is done before each start-up at the latest;
- Before emptying the ashpan, check that it does not contain any glowing remains of fuel that could cause a fire in the waste bin.

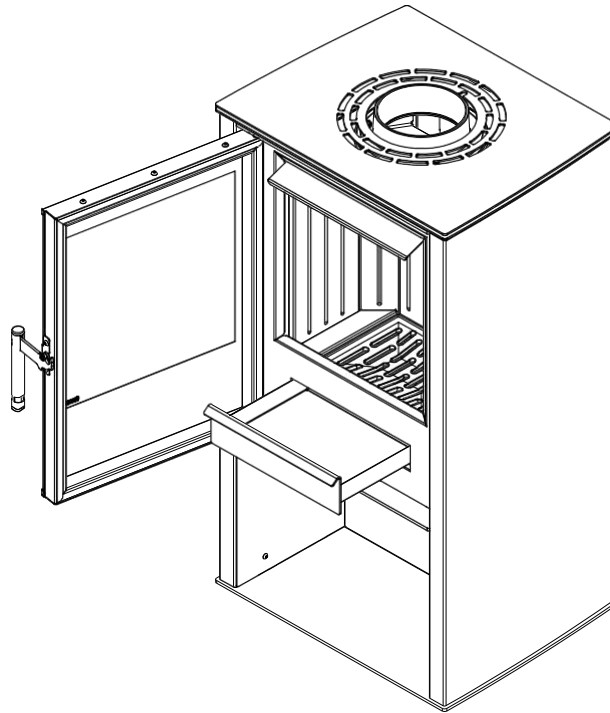

Fig. 17 Door open, ash pan partially extended

## NOTES:

**The manufacturer recommends that the ash pan should not be overfilled. The manufacturer recommends that the ash pan should not be overfilled. Overfilling the ash pan limits the air supply to the grate which results in poor combustion parameters and in extreme cases can make it impossible to light the cooker.**

If ash is left in the ash pan for too long, it can result in premature **corrosion**. The ash from burnt wood can be used for compost or as fertiliser.

## 4.7. Comments general

### You should:

- make sure that the **fire door (combustion chamber) is closed** (except when operating the cooker);
- after every prolonged break in operation, and before lighting the cooker again, carry out a patency check on the chimney flue and firebox;
- when carrying out any operations relating to the operation and use of the cooker, bear in mind that the cooker components may be hot, therefore **protective gloves** should be **used when operating** the cooker;
- For all repairs, use only spare parts from the cooker manufacturer;
- any repairs should only be carried out by a suitably qualified installer;
- During operation and use of the cooker, observe the rules that provide basic safety conditions.

### It is forbidden to:

- leave anything flammable or heat-sensitive near the glass of the cooker;
- operate the appliance with broken glass;
- extinguish fireplaces with water; w
- **allow children or animals to enter the appliance;**
- make any structural alterations, changes to the installation and operating principles without the manufacturer's written consent;
- **if you notice a malfunction, put the cooker out immediately.**

## **NOTES:**

**Emergency extinguishing of the cooker consists of filling the fuel with dry sand or cold ash.**

**WATER MUST NOT BE USED!**

**When working on a malfunctioning cooker, it is also necessary to ensure that the room is intensively ventilated and the operations are assisted by a second person equipped with a powder extinguisher.**

## **NOTES:**

As a result of slow combustion, large amounts of organic combustion products are released, resulting in the formation of creosote in the flue which can ignite. A so-called coke fire then occurs, from which the entire building can catch fire.

**In the event of a chimney fire, the following steps should be taken:**

- **shut off the air supply to the cooker by closing the cold air inlet dampers;**
- **close the rotary shaft in the flue system (if the system has one);**
- **close the oven door tightly;**
- **notify the nearest fire brigade 112 or 998.**

## **5. CONSERVATION**

In order to maintain safe and trouble-free operation of the unit, it is necessary to observe the following guidelines:

- carry out periodic and timely maintenance - at least once a year an inspection of the cooker by a specialised service;
- keep the glass, combustion chamber including ash pan and flue pipe reasonably clean;
- Empty the ash pan systematically - ash left for a long time can lead to corrosion of the ash pan;
- adjust the frequency of cleaning and maintenance of the combustion chamber to the type of fuel used;
- To clean steel or cast iron parts inside the cooker, use suitable tools such as a brush, scraper, poker, using protective gloves;
- **All maintenance must only be carried out on an extinguished and cooled appliance;**
- Clean the ceramic glass of the cooker with kitchen paper (paper towel). The glass should be moistened with water and cleaned with some clean ash from the inside of the stove, avoiding direct contact with the steel and cast iron parts of the appliance. The glass should be rubbed with the damp paper to effectively dissolve the ashes so that they can be wiped off with a dry steam towel. All agents and preparations used for cleaning the glass must not contain any abrasive materials that could damage (scratch) the glass;
- at least twice a year, have the flue pipes cleaned by an authorised chimney sweep, as documented in the Warranty Card;
- clean the inside of the cooker, check the intake and exhaust vents;
- all seals should be replaced before each heating season.



## 5.1. Recommended periodic cleaning of the cooker

In order to ensure efficient combustion in the firebox of the cooker, the combustion chamber, grate, chimney and flue pipes.

Element	Frequency	Tools and resources
Convection surfaces of the cooker and connecting pipes to the flue pipe - cleaning	As required, but at least once a year or after a prolonged break in operation	Spring material brush, ash extractor, fireplace cleaners.
Flue pipe, chimney - check patency of chimney and condition of flue system	At least twice a year, after the heating season and an extended break in operation.	Specialist chimney sweep
Front glass	As required	Cooled - dampened paper towel with a little clean ash, no abrasives to damage it
Grate and components inside the cooker	As required	Hoover, fireplace cleaners.
Maintenance of the exhaust throttle lever - replacement of glass gaskets and fire door	At least once a year, after the heating season or as required, depending on the level of consumption.	Service authorised by the manufacturer, lubrication with a small amount of graphite grease

For thorough cleaning of the cooker there is an inspection hole - a clean-out hatch - provided in the design, located at the rear of the cooker. To gain access to it, unscrew the rear cover of the cooker using an allen key. Details are shown in the diagram.

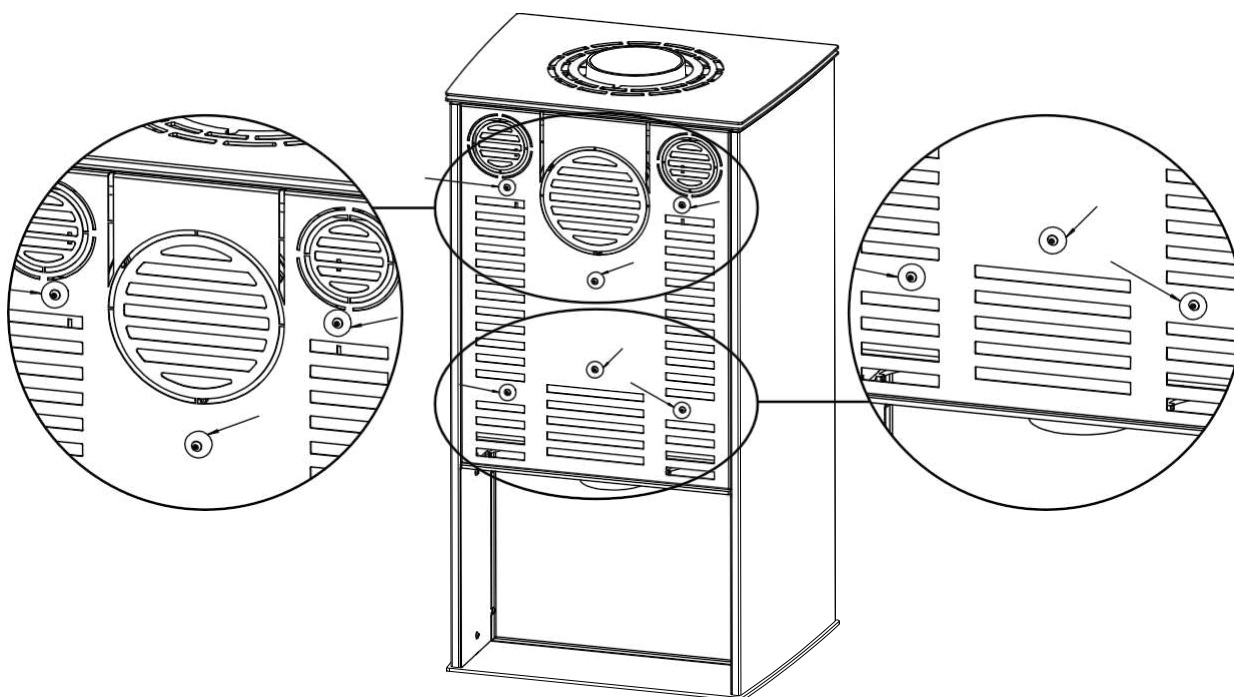
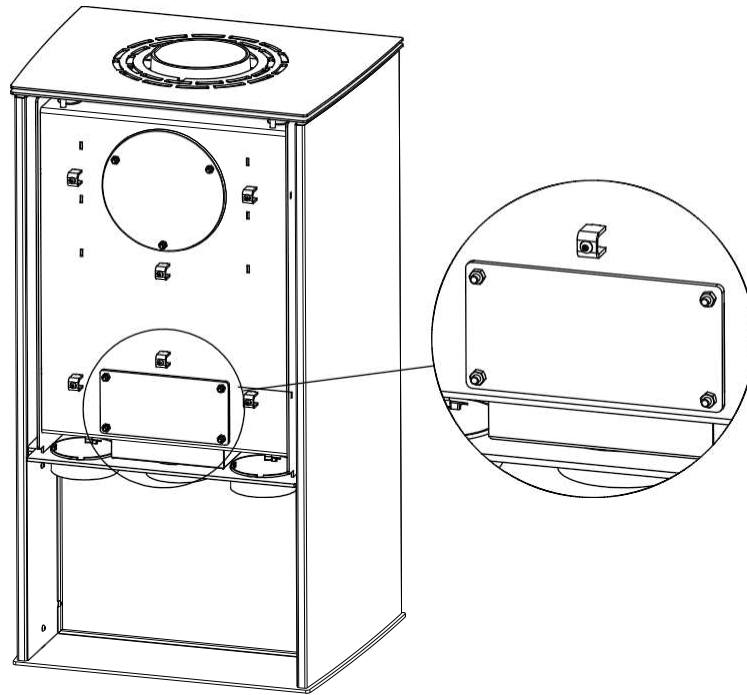

Fig. 18 Location of screws for rear furnace cover

Once the cover has been unscrewed, you will gain access to the cleanout. They are fastened with M8 nuts. It is advisable to use new sealing tape for reassembly after cleaning the inside of the cooker.



**Fig. 19** | Location of the cleanout

Thorough cleaning should be carried out once a year after the heating season, or as needed.

## 6. FAULTS AND ANOMALIES DURING OPERATION

During everyday use of the cooker, the following operating anomalies may occur which are indicative of incorrect installation of the cooker without observing the relevant instructions in this Operating and Installation Guide and the applicable laws.

### 6.1. The most common abnormalities and ways their solutions:

	<b>Problem</b>	<b>Solution</b>
Backflow of smoke inwards of the room when opening the cooker door	the door may have been opened too abruptly, causing negative pressure in the combustion chamber	slow door opening
	closed adjustable flue pipe shaft (if the installation has such an option)	opening the shaft
	insufficient air circulation in the room where the cooker is installed	check the efficiency of the ventilation and ensure that there is sufficient air in the room
	atmospheric conditions	
	inadequate flue draught	check the effectiveness of the installation chimney

Low productivity heating or phenomenon furnace extinction	insufficient fuel in the hearth	increase the amount of fuel to the required level
	fuel humidity too high	use wood with a moisture content of up to 20%
	inadequate flue draught	check the efficiency of the chimney installation
Low heating capacity with correct combustion process in the furnace	unsuitable, low- calorific wood was used	change to a more calorific type of wood burned
	fuel humidity too high	use wood with a moisture content of up to 20%
	thin, fine pieces of wood are used which burn quickly	use for smoking other thicker clearing
Dirty glass, no self-burning glass	too slow a fuel combustion resulting in low combustion chamber temperature	increase the amount of air in the combustion chamber, use wood with a moisture content of up to 20%
	coniferous woods with high resin content were used	change wood species to dry hardwoods
Failure of the unit to operate correctly may be due to external factors	tall objects too close to the chimney	increase the height of the chimney or use a "fireman" or other type of cowl
	unsuitable atmospheric conditions, e.g. wind or lack of wind, low atmospheric pressure, high atmospheric humidity, fog, etc.	use a chimney pot, but if this does not help, a chimney sweep should be employed to determine the source of the problem

## 7. NAMEPLATE

The rating plate is located on the rear of the unit.

<b>HITZE</b>		STALKO Spółka z ograniczoną odpowiedzialnością sp. k. ul. Solec 24/25B, 00-402 Warszawa POLAND		<b>CE</b> 22 NB 1015	
<b>Wkład kominkowy stalopalny</b> Fireplace Insert for constant burning / Kaminsnitz dauerbrand					
Norma odniesienia: Technischer Standard / Polish Norm		PN-EN 16510-1:2018-08			
Nazwa / Name / Name -		Lupo S / Lupo S / Lupo S			
Typ / Type / Typ :	Lupo S	Certyfikat nr / Certificate nr / Zertifikat Nummer :	E-30-00008-18		
Nr fabryczny / Serial Number / Seriennummer :	000002 / 2021	Klasa kominka / Insert class / Kaminsitzklasse :	1a		
Nominalna moc ciepła / Nominal heat output / Nennwärmeleistung :	nom. 6,5 kW min. 3,0 kW	Maksymalne ciśnienie robocze / Maximum operating pressure / Maximaler Betriebsdruck :			
Moc ciepła wody / Water heating capacity / Wasserwärmeleistung :	nom. 8,5 kW min. 3,0 kW	Typ paliwa / Fuel type / Brennstofftyp :	Drewno liściaste / Hartholz / Hartholz		
Moc grzewcza w pomieszczeniu / Room heating capacity / Raumwärmeleistung :	nom. 83,0 %				
Sprawność ciepła / Thermal efficiency / Wirkungsgrad :	nom. 1,080 g/m <sup>3</sup>				
Emisja CO (13% O <sub>2</sub> ) / CO Emission / Wasserdampfabgabe :	nom. 0,038 g/m <sup>3</sup>				
Emisja Pyłu (13% O <sub>2</sub> ) / Dust Emission / Staubemissionen :	nom. 235°C				
Srednia temperatura spalin / The average temperature of the exhaust gas / Abgas Temperatur am Starten :	Minimalny odstęp od materiałów palnych / Minimal distance from flammable materials / Mindestabstand zu brennbaren Materialien		- ściana przednia / front wall / vorderwand 300 cm - ściana tylna / rear wall / hinterwand 200 cm - ściany boczne / side walls / reitewände 300 cm		
Uwagi / notes / comments : Należy przeczytać i stosować się do instrukcji / Be sure to read and follow the user guide / Bitte befolgen Sie die Anweisungen der Bedienungsanleitung Używać wyłącznie zalecanego paliwa / Use only recommended fuels / Nur die empfohlenen Brennstoffe verwenden					

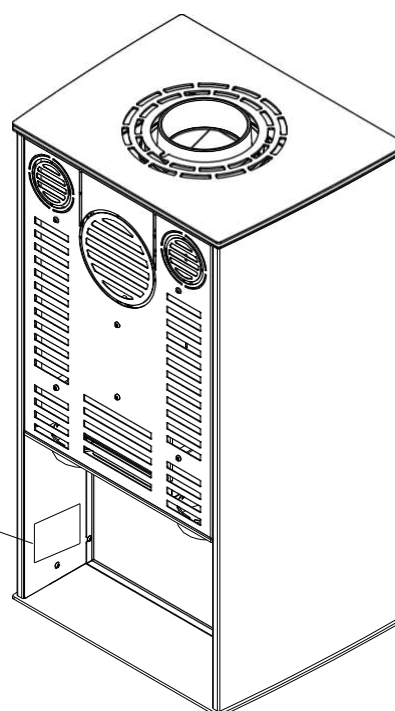

Fig. 20 Model of rating plate and its location

## 8. CARD REVIEWS

FURNACE INSPECTION LOG	
Overview	Date, signature and stamp
Overview	Date, signature and stamp
Overview	Date, signature and stamp
Overview	Date, signature and stamp
Overview	Date, signature and stamp
Overview	Date, signature and stamp

## FLUE INSPECTION LOG

Overview

Date, signature and stamp

Overview

Date, signature and stamp

Overview

Date, signature and stamp

Overview

Date, signature and stamp

Overview

Date, signature and stamp

Overview

Date, signature and stamp

# HITZE

PRODUCER OF FIREPLACES



HitzeProducentKominkow



hitze\_producent\_kominkow



HITZE Producent Kominków

STALKO  
spółka z ograniczoną odpowiedzialnością  
spółka komandytowa  
ul. Solec 24/253  
00-403 Warszawa, POLSKA

Biuro:  
Gdyńska 32  
26-600 Radom  
POLSKA

 +48 48 380 18 98  
+48 800 88 00 30

 [info@hitze.pl](mailto:info@hitze.pl)

NIP 9482603545  
REGON 361379132  
KRS 0000836475

[www.hitze.pl](http://www.hitze.pl)